



EDUS 39 - 900 - F8

R-410A

Engineering Data

BSVQ-P
BS units



DAIKIN AC (AMERICAS), INC.

BSVQ-P BS units

1. Specifications	2
2. Dimensions	3
3. Piping diagrams	6
4. Wiring diagrams	7
5. Electric characteristics	8
6. Safety devices setting	9
7. Sound levels.....	10
7.1 Overall	10
7.2 Octave band level.....	10
8. Center of gravity	11
9. Installation	12

1. Specifications

BS units

Model		BSVQ36PVJU		BSVQ60PVJU		BSVQ96PVJU	
Power supply		1 phase 60Hz 208-230V		1 phase 60Hz 208-230V		1 phase 60Hz 208-230V	
Total capacity index of connectable indoor unit		Less than 36		Less than 60		Less than 96	
No. of connectable indoor units		Max. 5		Max. 8		Max. 8	
Casing		Galvanized steel plate		Galvanized steel plate		Galvanized steel plate	
Dimensions: (HxWxD)		in.	8-1/8 x 15-1/4 x 12-13/16	in.	8-1/8 x 15-1/4 x 12-13/16	in.	8-1/8 x 15-1/4 x 12-13/16
Sound absorbing thermal insulation material		Foamed polyurethane. Frame resisting needle felt.		Foamed polyurethane. Frame resisting needle felt.		Foamed polyurethane. Frame resisting needle felt.	
Piping connection	Indoor unit	Liquid pipes	in.	φ 3/8 C1220T (Brazeing connection) ★1	φ 3/8 C1220T (Brazeing connection)	φ 3/8 C1220T (Brazeing connection)	
		Gas pipes	in.	φ 5/8 C1220T (Brazeing connection) ★1	φ 5/8 C1220T (Brazeing connection) ★2	φ 7/8 C1220T (Brazeing connection) ★3	
	Outdoor unit	Liquid pipes	in.	φ 3/8 C1220T (Brazeing connection)	φ 3/8 C1220T (Brazeing connection)	φ 3/8 C1220T (Brazeing connection)	
		Suction gas pipes	in.	φ 5/8 C1220T (Brazeing connection)	φ 5/8 C1220T (Brazeing connection) ★2	φ 7/8 C1220T (Brazeing connection) ★3	
		Discharge gas pipes	in.	φ 1/2 C1220T (Brazeing connection)	φ 1/2 C1220T (Brazeing connection) ★2	φ 3/4 C1220T (Brazeing connection) ★3	
	Mass (Weight)		Lbs	26	Lbs	26	Lbs
Standard accessories		Installation manual. Attached pipe. Insulation pipe cover. Clamps.		Installation manual. Attached pipe. Insulation pipe cover. Clamps.		Installation manual. Attached pipe. Insulation pipe cover. Clamps.	
Drawing No.		4D058233A		4D058234A		4D065539	

Notes:

- ★1 In case of connecting with a 07~18 type indoor unit, match to the size of field pipe using the attached pipe.
(Connection between the attached pipe and the field pipe must be brazed.)
- ★2 In case of connecting with indoor unit capacity index 54 or more and 60 or less, match to the size of the field pipe using the attached pipe.
(Connection between the attached pipe and the field pipe must be brazed.)
- ★3 In case of connecting with a 72 type indoor unit or indoor unit capacity index more than 60 and less than 72, match to the size of the field pipe using the attached pipe.
(Connection between the attached pipe and the field pipe must be brazed.)

2. Dimensions

BSVQ36PVJU

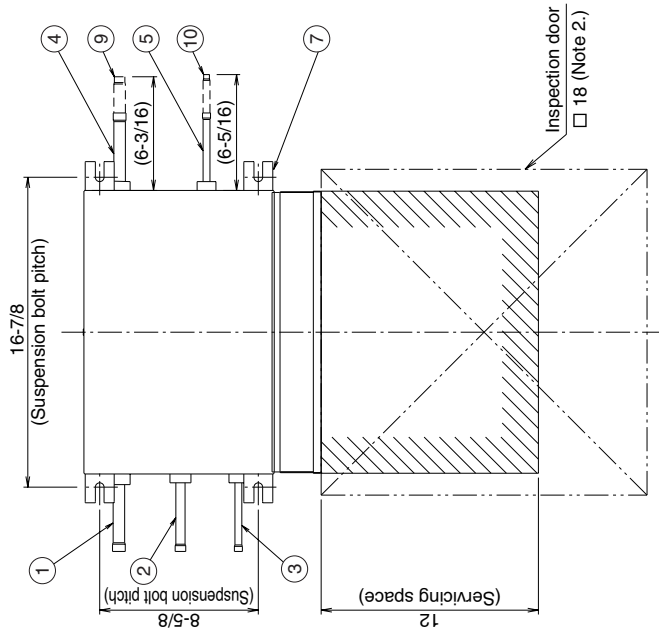
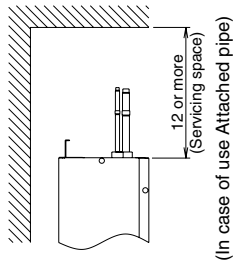
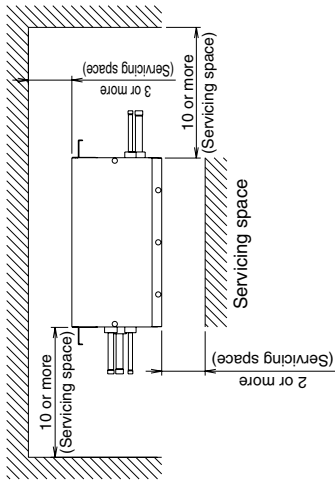

- Notes) 1. Electric box can also be fixed on the other side of the unit.
 2. Be sure to install an inspection door at electric box side.
 3. Attached pipe is only used in case of connecting with a 07~18 class indoor unit.
 4. Small sound of refrigerant will be made, which may be disturbing.
 Do not install it at the place such as bedroom under roof.

Number	Part name	Description
10	Attached pipe (2) (Note. 3)	φ 1/4 brazing connection
9	Attached pipe (1) (Note. 3)	φ 1/2 brazing connection
8	Grounding terminal	M4
7	Suspension brackets	MB-M10
6	Electric box (Note 1.)	
5	Liquid pipe connection port	φ 3/8 brazing connection
4	Gas pipe connection port	φ 5/8 brazing connection
3	Liquid pipe connection port	φ 3/8 brazing connection
2	HPLP gas pipe connection port	φ 1/2 brazing connection
1	Suction gas pipe connection port	φ 5/8 brazing connection

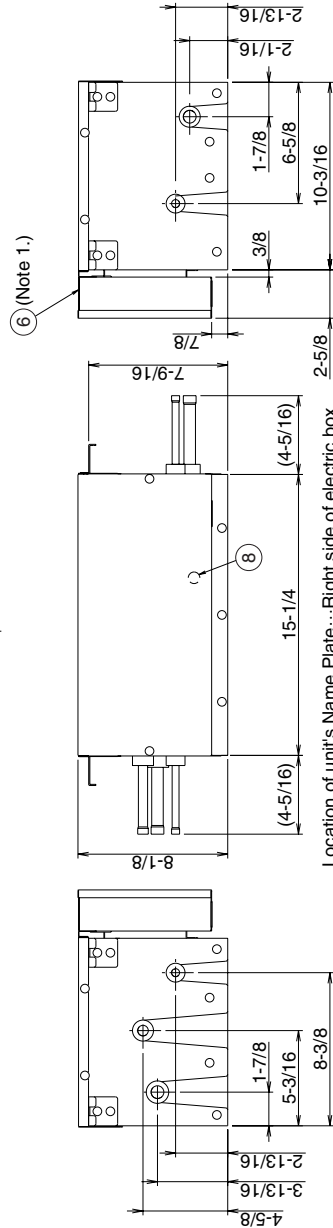

Location of unit's Name Plate...Right side of electric box

3D058236

BSVQ60PVJU

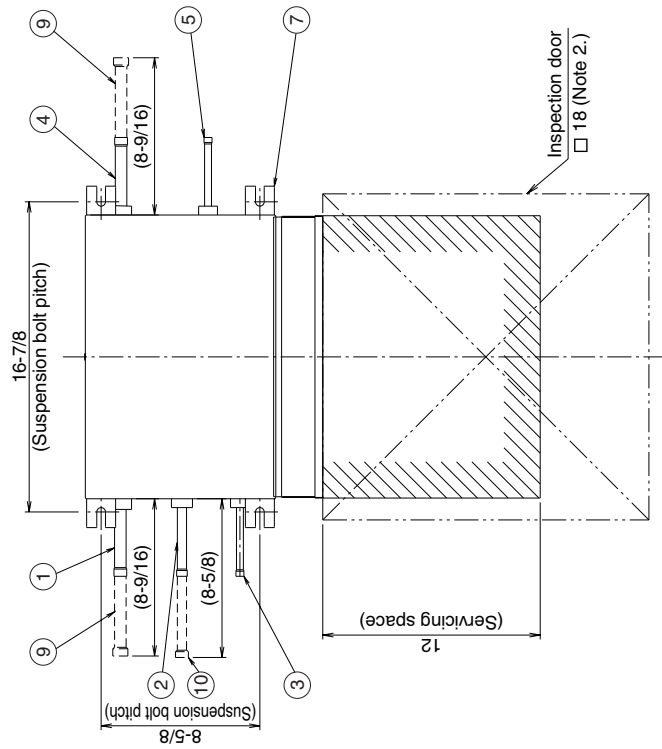
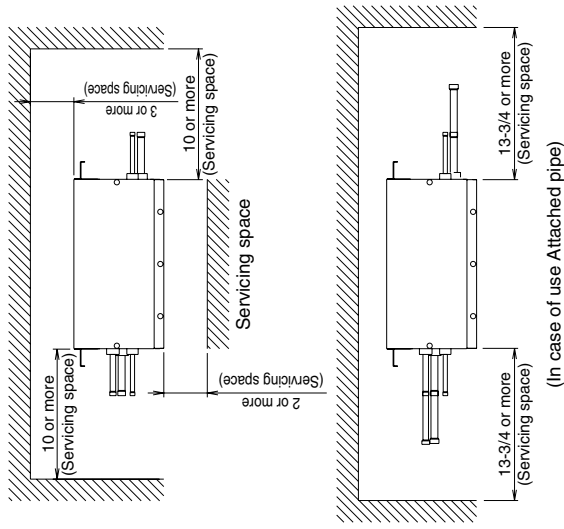

- Notes
1. Electric box can also be fixed on the other side of the unit.
 2. Be sure to install an inspection door at electric box side.
 3. Attached pipe is only used in case of connecting with indoor unit capacity index 54 or more and 60 or less.
 4. Small sound of refrigerant will be made, which may be disturbing.
Do not install it at the place such as bedroom under roof.

Number	Part name	Description
10	Attached pipe (2) (Note. 3)	φ 5/8 brazing connection
9	Attached pipe (1) (Note. 3)	φ 3/4 brazing connection
8	Grounding terminal	M4
7	Suspension brackets	MB-M10
6	Electric box (Note 1.)	
5	Liquid pipe connection port	φ 3/8 brazing connection
4	Gas pipe connection port	φ 5/8 brazing connection
3	Liquid pipe connection port	φ 3/8 brazing connection
2	HP/LP gas pipe connection port	φ 1/2 brazing connection
1	Suction gas pipe connection port	φ 5/8 brazing connection

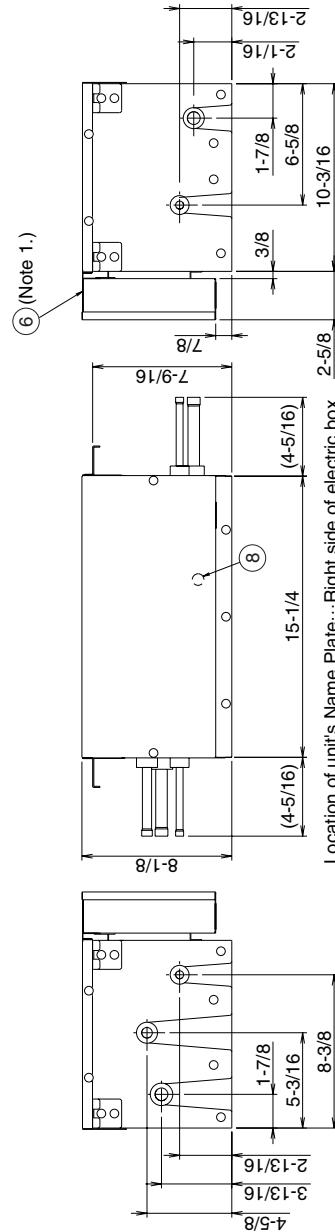

Location of unit's Name Plate...Right side of electric box

3D056237

BSVQ96PVJU

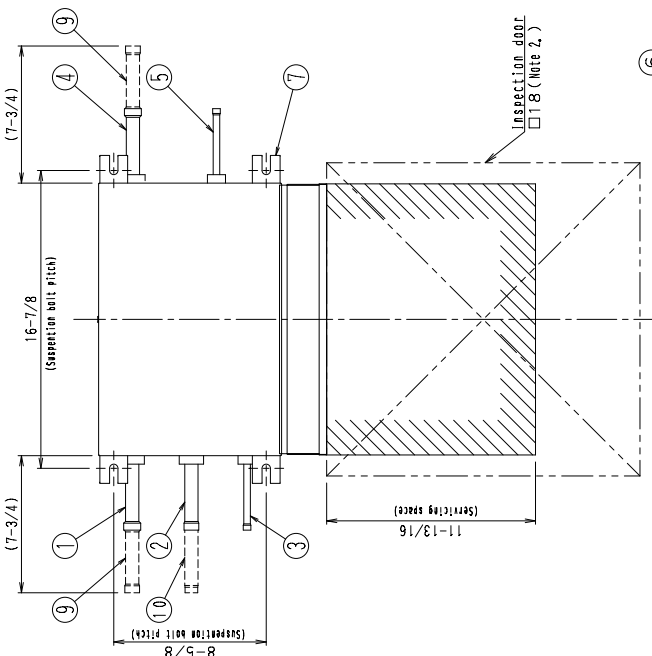
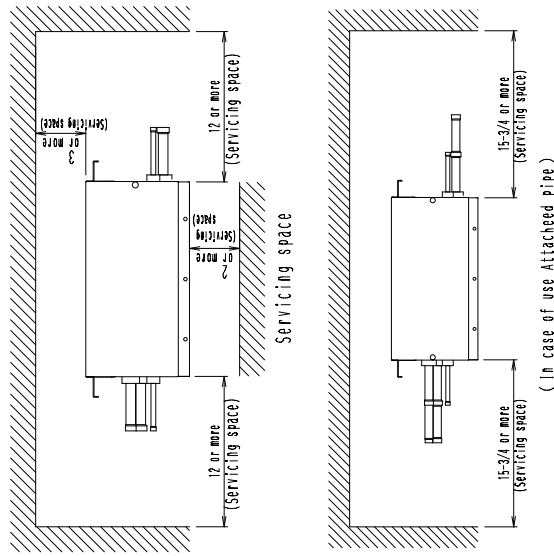

- Notes) 1. Electric box can also be fixed on the other side of the unit.
 2. Be sure to install an inspection door at electric box side.
 3. Attached Pipe(1) and Attached pipe(2) is used in case of connecting with indoor capacity index more than 60 and less than 72.
 In case of connecting one indoor unit of 72 type, only gas pipe connection port need Attached pipe(1), Small sound will be made when changing over the motor operated valve, which may be disturbing. Do not install it at the place such as bedroom under roof.

NUMBER	PART NAME	DESCRIPTION
10	Attached pipe(2) (Note.3)	φ5/8 brazing connection
9	Attached Pipe(1) (Note.3)	φ3/4 brazing connection
8	Grounding terminal	M4
7	Suspension brackets	MB-M10
6	Electric box (Note 1.)	
5	Liquid pipe connection part	φ3/8 brazing connection
4	Gas pipe connection part	φ7/8 brazing connection
3	Liquid pipe connection part	φ3/8 brazing connection
2	HP/IP gas pipe connection port	φ3/4 brazing connection
1	Suction gas pipe connection port	φ7/8 brazing connection

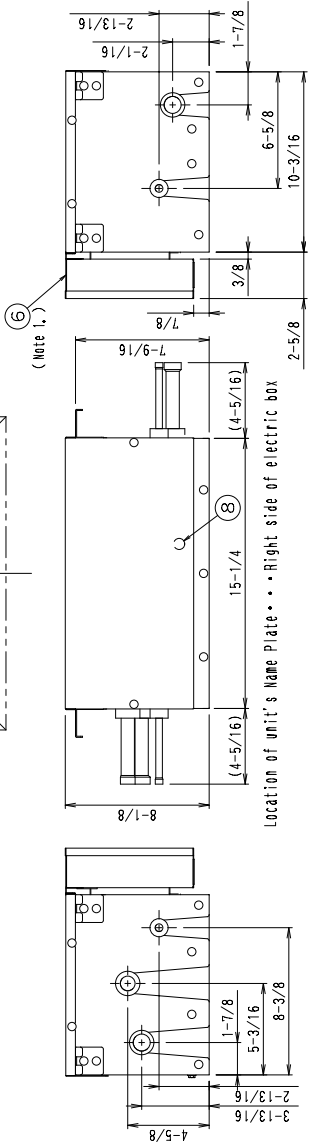

3D065540

3. Piping diagrams

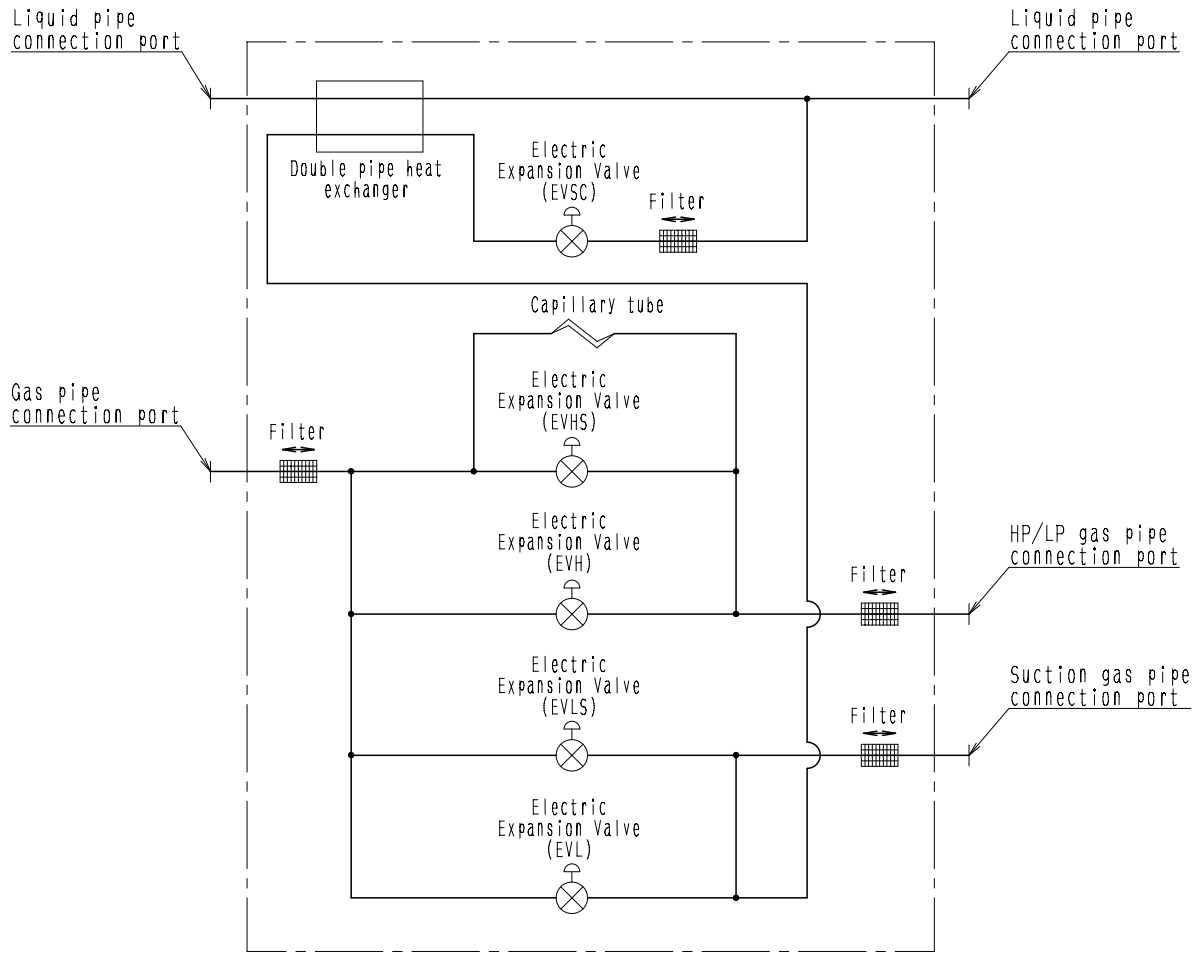

4D057985B

4. Wiring diagrams

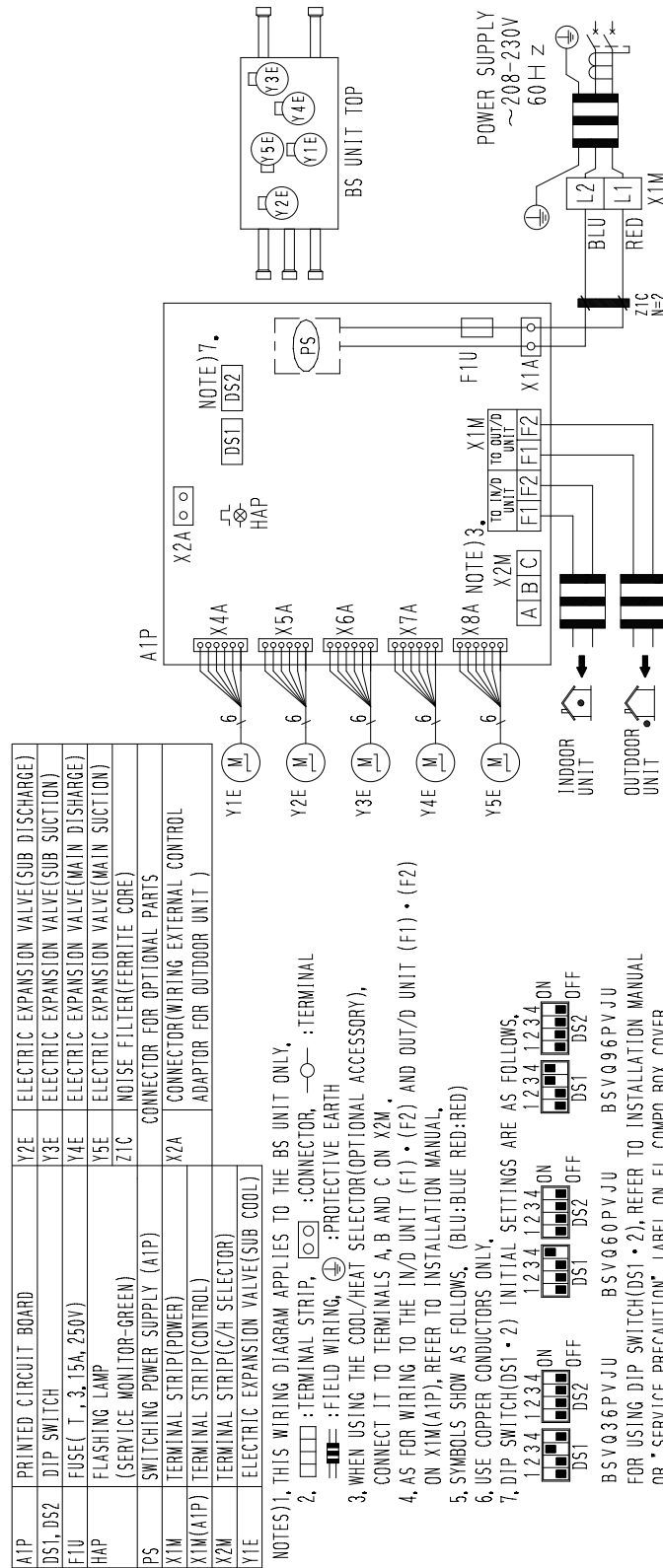

3D058235C

5. Electric characteristics

Model	Units			Power supply		IFM		Input(W)	
	Hz	Volts	Voltage range	MCA	MFA	KW	FLA	Cooling	Heating
BSVQ36PVJU	60	208-230	MAX. 253 Min. 187	0.1	15	—	—	5	5
BSVQ60PVJU				0.1	15	—	—	5	5
BSVQ96PVJU				0.1	15	—	—	5	5

Symbols :

MCA : Min. Circuit Amps (A)
 MFA : Max. Fuse Amps (A) (See note 5)
 KW : Fan Motor Rated Output(KW)
 FLA : Full Load Amps(A)
 IFM : Indoor Fan Motor

Note :

- Voltage range
Units are suitable for use on electrical systems where voltage supplied to unit terminals is not below or above listed range limits,
- Maximum allowable voltage unbalance between phases is 2%.
- MCA/MFA
 $MCA = 1.25 \times FLA$
 $MFA \leq 4 \times FLA$
 (Next lower standard fuse rating. Min. 15A)
- Select wire size based on the MCA.
- Instead of fuse, use Circuit Breaker.

4D058238A

6. Safety devices setting

Model	BSVQ36PVJU	BSVQ60PVJU	BSVQ96PVJU
PC board fuse	250V 3.15A	250V 3.15A	250V 3.15A

4D057956B

7. Sound levels

7.1 Overall

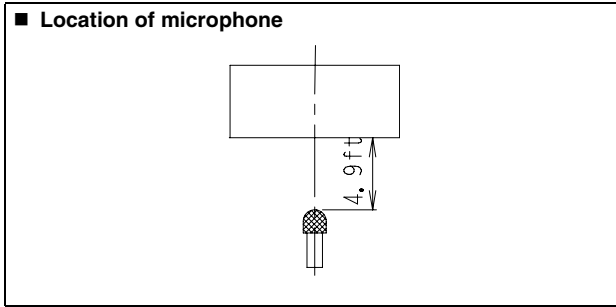

Notes:

1. Operation noise differs with operation and ambient conditions.
2. In case of other unit operating in the same system, operating sound will be generated, even if indoor unit connected to BS unit is stopped.
3. These sound levels are based on JIS standard and sound data are reference.

dBA

Model	208~230V, 60Hz	
	Operating Sound	Stoppage Sound
BSVQ36PVJU	42	32
BSVQ60PVJU	43	32
BSVQ96PVJU	44	34

7.2 Octave band level

○ — ○ 208~230V, 60Hz

BSVQ36PVJU (Reference)

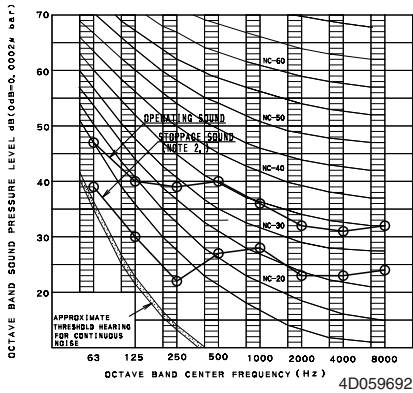

BSVQ60PVJU (Reference)

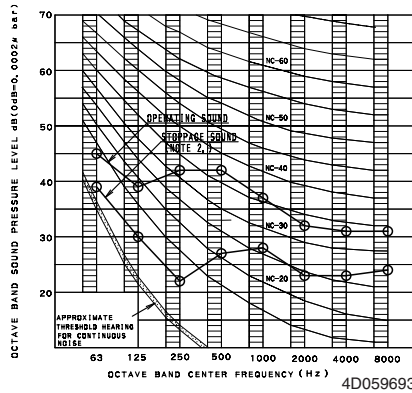

BSVQ96PVJU (Reference)

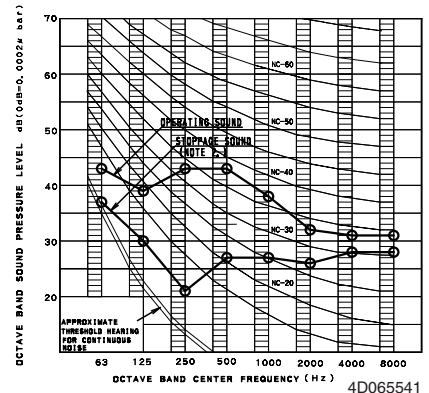

8. Center of gravity

BSVQ36PVJU
BSVQ60PVJU

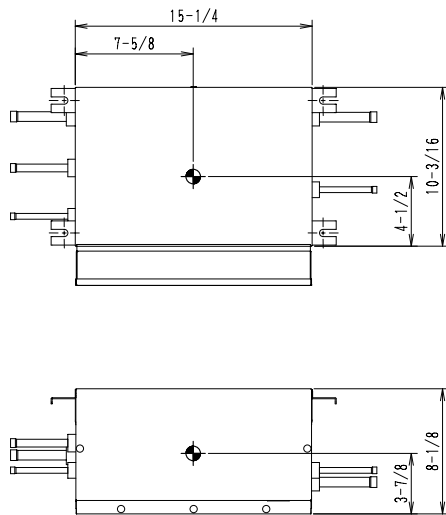

IN CASE OF THE ELECTRICAL BOX ON THE STANDARD SIDE OF THE UNIT

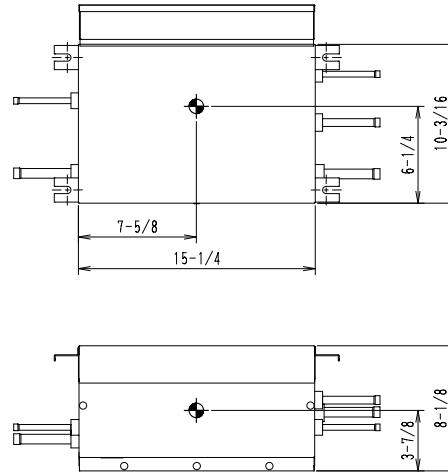

IN CASE OF THE ELECTRICAL BOX ON THE OTHER SIDE OF THE UNIT

3D059694

BSVQ96PVJU

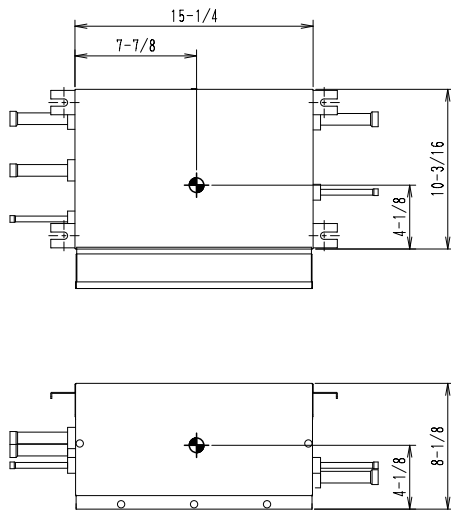

IN CASE OF THE ELECTRICAL BOX ON THE STANDARD SIDE OF THE UNIT

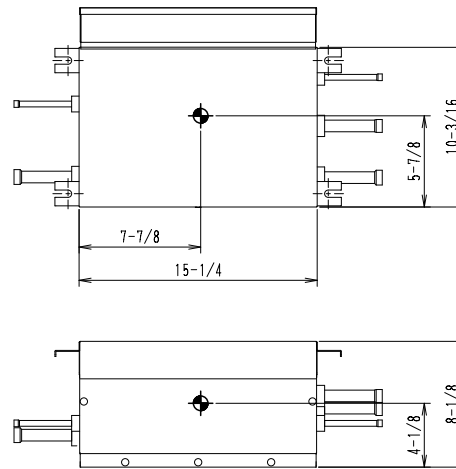

IN CASE OF THE ELECTRICAL BOX ON THE OTHER SIDE OF THE UNIT

3D065542

9. Installation



BSVQ36PVJU
BSVQ60PVJU
BSVQ96PVJU

VRVIII SYSTEM Air Conditioners

Installation manual

CONTENTS

1 SAFETY CONSIDERATIONS	1
2 BEFORE INSTALLATION	4
3 SELECTING INSTALLATION SITE	5
4 PREPARATIONS BEFORE INSTALLATION.....	6
5 BS UNIT INSTALLATION.....	7
6 REFRIGERANT PIPING WORK	8
7 ELECTRIC WIRING WORK.....	13
8 INITIAL SETTING.....	16
9 TEST OPERATION	17

1. SAFETY CONSIDERATIONS

Read these **SAFETY CONSIDERATIONS for Installation** carefully before installing air conditioning equipment. After completing the installation, make sure that the unit operates properly during the startup operation. Instruct the customer on how to operate and maintain the unit. Inform customers that they should store this Installation Manual with the Operation Manual for future reference.

Always use a licensed installer or contractor to install this product. Improper installation can result in water or refrigerant leakage, electrical shock, fire, or explosion.

Meanings of **DANGER**, **WARNING**, **CAUTION**, and **NOTE** Symbols:

 **DANGER** Indicates an imminently hazardous situation which, if not avoided, will result in death or serious injury.

 **WARNING** Indicates a potentially hazardous situation which, if not avoided, could result in death or serious injury.

 **CAUTION** Indicates a potentially hazardous situation which, if not avoided, may result in minor or moderate injury. It may also be used to alert against unsafe practices.

 **NOTE** Indicates situation that may result in equipment or property-damage accidents only.

 **DANGER** —————

- Refrigerant gas is heavier than air and replaces oxygen. A massive leak could lead to oxygen depletion, especially in basements, and an asphyxiation hazard could occur leading to serious injury or death.
- Do not ground units to water pipes, gas pipes, telephone wires, or lightning rods as incomplete grounding can cause a severe shock hazard resulting in severe injury or death. Additionally, grounding to gas pipes could cause a gas leak and potential explosion causing severe injury or death.
- If refrigerant gas leaks during installation, ventilate the area immediately. Refrigerant gas may produce toxic gas if it comes in contact with fire. Exposure to this gas could cause severe injury or death.

- After completing the installation work, check that the refrigerant gas does not leak throughout the system.
- Do not install unit in an area where flammable materials are present due to risk of explosions that can cause serious injury or death.
- Safely dispose all packing and transportation materials in accordance with federal/state/local laws or ordinances. Packing materials such as nails and other metal or wood parts, including plastic packing materials used for transportation may cause injuries or death by suffocation.

⚠ WARNING

- Only qualified personnel must carry out the installation work. Installation must be done in accordance with this installation manual. Improper installation may result in water leakage, electric shock, or fire.
- When installing the unit in a small room, take measures to keep the refrigerant concentration from exceeding allowable safety limits. Excessive refrigerant leaks, in the event of an accident in a closed ambient space, can lead to oxygen deficiency.
- Use only specified accessories and parts for installation work. Failure to use specified parts may result in water leakage, electric shocks, fire, or the unit falling.
- Install the air conditioner on a foundation strong enough that it can withstand the weight of the unit. A foundation of insufficient strength may result in the unit falling and causing injuries.
- Take into account strong winds, typhoons, or earthquakes when installing. Improper installation may result in the unit falling and causing accidents.
- Make sure that a separate power supply circuit is provided for this unit and that all electrical work is carried out by qualified personnel according to local state, and national regulations. An insufficient power supply capacity or improper electrical construction may lead to electric shocks or fire.
- Make sure that all wiring is secured, that specified wires are used, and that no external forces act on the terminal connections or wires. Improper connections or installation may result in fire.
- When wiring, position the wires so that the electrical components box lid can be securely fastened. Improper positioning of the electrical components box lid may result in electric shocks, fire, or the terminals overheating.
- Before touching electrical parts, turn off the unit.
- It is recommended to install a ground fault circuit interrupter if one is not already available. This helps prevent electrical shocks or fire.
- Securely fasten the outside unit terminal cover (panel). If the terminal cover/panel is not installed properly, dust or water may enter the outside unit causing fire or electric shock.
- When installing or relocating the system, keep the refrigerant circuit free from substances other than the specified refrigerant (R-410A) such as air. Any presence of air or other foreign substance in the refrigerant circuit can cause an abnormal pressure rise or rupture, resulting in injury.
- Do not change the setting of the protection devices. If the pressure switch, thermal switch, or other protection device is shorted and operated forcibly, or parts other than those specified by Daikin are used, fire or explosion may occur.

⚠ CAUTION

- Do not touch the switch with wet fingers. Touching a switch with wet fingers can cause electric shock.
- Do not allow children to play on or around the unit to prevent injury.
- Do not touch the refrigerant pipes during and immediately after operation as the refrigerant pipes may be hot or cold, depending on the condition of the refrigerant flowing through the refrigerant piping, compressor, and other refrigerant cycle parts. Your hands may suffer burns or frostbite if you touch the refrigerant pipes. To avoid injury, give the pipes time to return to normal temperature or, if you must touch them, be sure to wear proper gloves.
- Heat exchanger fins are sharp enough to cut.
To avoid injury wear gloves or cover the fins when working around them.

- Install drain piping to proper drainage. Improper drain piping may result in water leakage and property damage.
- Insulate piping to prevent condensation.
- Be careful when transporting the product.
- Do not turn off the power immediately after stopping operation. Always wait for at least 5 minutes before turning off the power. Otherwise, water leakage may occur.
- Do not use a charging cylinder. Using a charging cylinder may cause the refrigerant to deteriorate.
- Refrigerant R-410A in the system must be kept clean, dry, and tight.
 - (a) Clean and Dry -- Foreign materials (including mineral oils such as SUNISO oil or moisture) should be prevented from getting into the system.
 - (b) Tight -- R-410A does not contain any chlorine, does not destroy the ozone layer, and does not reduce the earth's protection against harmful ultraviolet radiation. R-410A can contribute to the greenhouse effect if it is released. Therefore take proper measures to check for the tightness of the refrigerant piping installation. Read the chapter Refrigerant Piping and follow the procedures.
- Since R-410A is a blend, the required additional refrigerant must be charged in its liquid state. If the refrigerant is charged in a state of gas, its composition can change and the system will not work properly.
- The indoor unit is for R-410A. See the catalog for indoor models that can be connected. Normal operation is not possible when connected to other units.
- Remote controller (wireless kit) transmitting distance can be shorter than expected in rooms with electronic fluorescent lamps (inverter or rapid start types). Install the indoor unit far away from fluorescent lamps as much as possible.
- Indoor units are for indoor installation only. Outdoor units can be installed either outdoors or indoors.
- Do not install the air conditioner in the following locations:
 - (a) Where a mineral oil mist or oil spray or vapor is produced, for example, in a kitchen. Plastic parts may deteriorate and fall off or result in water leakage.
 - (b) Where corrosive gas, such as sulfuric acid gas, is produced. Corroding copper pipes or soldered parts may result in refrigerant leakage.
 - (c) Near machinery emitting electromagnetic waves. Electromagnetic waves may disturb the operation of the control system and cause the unit to malfunction.
 - (d) Where flammable gas may leak, where there is carbon fiber, or ignitable dust suspension in the air, or where volatile flammables such as thinner or gasoline are handled. Operating the unit in such conditions can cause a fire.
- Take adequate measures to prevent the outside unit from being used as a shelter by small animals. Small animals making contact with electrical parts can cause malfunctions, smoke, or fire. Instruct the customer to keep the area around the unit clean.

 **NOTE**

- Install the power supply and control wires for the indoor and outdoor units at least 3.5 feet away from televisions or radios to prevent image interference or noise. Depending on the radio waves, a distance of 3.5 feet may not be sufficient to eliminate the noise.
 - Dismantling the unit, treatment of the refrigerant, oil and additional parts must be done in accordance with the relevant local, state, and national regulations.
 - Do not use the following tools that are used with conventional refrigerants: gauge manifold, charge hose, gas leak detector, reverse flow check valve, refrigerant charge base, vacuum gauge, or refrigerant recovery equipment.
 - If the conventional refrigerant and refrigerator oil are mixed in R-410A, the refrigerant may deteriorate.
 - This air conditioner is an appliance that should not be accessible to the general public.
 - The wall thickness of field-installed pipes should be selected in accordance with the relevant local, state, and national regulations.
-

NOTE

The refrigerant R410A requires strict cautions for keeping the system clean, dry and tight.

- A. Clean and dry
Foreign materials (including mineral oils such as SUNISO oil or moisture) should be prevented from getting mixed into the system.
- B. Tight
R410A does not contain any chlorine, does not destroy the ozone layer, and does not reduce the earth's protection against harmful ultraviolet radiation.
R410A can contribute slightly to the greenhouse effect if it is released. Therefore we should take special attention to check the tightness of the installation.
Read the chapter "Refrigerant piping work" carefully and follow these procedures correctly.

2. BEFORE INSTALLATION

2-1 CAUTION CONCERNING NEW REFRIGERANT SERIES

- Since R410A is a mixed refrigerant, the required additional refrigerant must be charged in its liquid state. (If the refrigerant is charged in a state of gas, its composition changes and the system will not work properly.)
The indoor/outside unit is for R410A. See the catalog for indoor/outside unit models which can be connected. (Normal operation is not possible when connected to other units.)

2-2 PRECAUTIONS

- Hold the unit by the Hanging brackets (4 points) when opening the box and moving it, and do not lift it holding on to any other part especially the refrigerant piping.
- About installation of outside and indoor unit, refer to the installation manual provided with the outside and the indoor unit.
- This unit, both indoor and outside, is suitable for installation in a commercial and light industrial environment. If installed as a household appliance it could cause electromagnetic interference.









2-3 ACCESSORIES

Check the following accessories are included with your unit.







NOTE

- Do not throw away any of the accessories until installation is complete.

<BSVQ36 · 60PVJU>

Name	1) Accessory pipes		1) Accessory pipes		2) Clamp		3) Insulation tube		Explanation Document
	(BSVQ36 only)		(BSVQ60 only)						
Quantity	1 pc.	1 pc.	1 pc.	2 pcs.	6 pcs.	10 pcs.	2 pcs.	3 pcs.	1 copy
Shape	 φ3/8	 φ5/8	 φ1/2	 φ5/8	 (Small)	 (Large)	 (Small)	 (Large)	Installation manual

<BSVQ96PVJU>

Name	1) Accessory pipes		2) Clamp		3) Insulation tube			Explanation Document
	1 pc.	2 pcs.	6 pcs.	10 pcs.	2 pcs.	2 pcs.	1 pc.	
Quantity	1 pc.	2 pcs.	6 pcs.	10 pcs.	2 pcs.	2 pcs.	1 pc.	1 copy
Shape	 φ3/4	 φ3/4	 (Small)	 (Large)	 (Small)	 (Medium)	 (Large)	Installation manual

2-4 COMBINATION

- This BS unit is only applicable to VRV-III (REYQ__P) or VRV-WIII (RWEYQ__P) series equipment. It cannot be connected to older generation VRV systems (REYQ_M).
- For series of applicable indoor units, refer to the catalog or other literature.
- Select the BS unit to fit the total capacity (sum of unit's capacity) and max. number of the indoor units to be connected downstream. About indoor unit's capacity, refer to the Table 2.

Table 1

Model	Total capacity of all downstream indoor units	Max. number of all downstream indoor units
BSVQ36PVJU	$A \leq 36$	5
BSVQ60PVJU	$36 < A \leq 60$	8
BSVQ96PVJU	$60 < A \leq 96$	8

Table 2

Capacity expressed as indoor unit's model No.	07	09	12	18	24	30	36	48	72	96
Indoor unit's capacity (for use in computation)	7.5	9.5	12	18	24	30	36	48	72	96

<Example>

In case of the BS unit which connect two FXFQ12M and two FXSQ18M.

Total capacity = $12 \times 2 + 18 \times 2 = 60 \rightarrow$ **Select BSVQ60PVJU**

2-5 CHECK ITEM

- For the following items, take special care during construction and check after installation is finished.

Completion check items

Check items	Problems	Check
Are the BS units installed securely?	Falling, vibration, and operating noise	
Have you performed a gas leak test?	Does not cool or heat	
Is the insulation complete? (Refrigerant piping and pipe connection part)	Water leaking	
Is the voltage the same as that listed on the unit's nameplate?	Does not operate/burnt out	
Are all the wiring and piping correct?	Does not operate/burnt out	
Is the unit grounded?	Dangers during electrical leak	
Is the thickness of the power cord as specified?	Does not operate/burnt out	

Hand-over check items

Check items	Check
Did you close the Electrical Components Box lid?	
Did you hand the operating manual and warranty card to the customer?	

3. SELECTING INSTALLATION SITE

Select an installation site where the following conditions are satisfied and that meets with your customer's approval.

- Where is resistible against weight of BS unit.
- Locations where the wall is not significantly tilted.
- Where sufficient clearance for maintenance and service can be ensured. (**Refer to Fig. 1**)
- Locations where an inspection hole (**Refer to Fig. 2**) can be installed to Electrical Components Box side (See Note).
- Where the total piping length involving indoor unit and outside unit is below the allowable piping length. (See installation manual attached to outside unit.)

Note: The Electrical Components Box mounting surface can be changed.
 For information on how to change the mounting surface, refer to “5. BS UNIT INSTALLATION”.

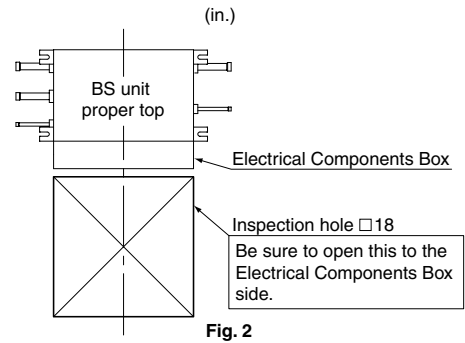
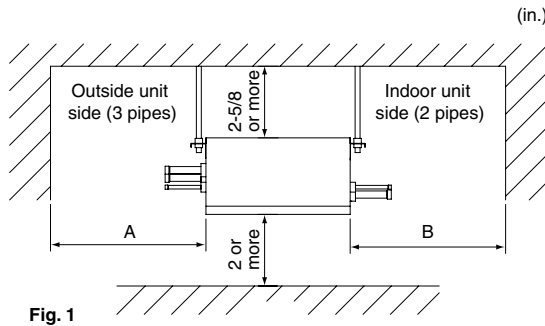

BS Unit Name	A	B
BSVQ36P	10 or more	10 or more (*1)
BSVQ60P	10 or more (*2)	10 or more (*2)
BSVQ96P	12 or more (*3)	12 or more (*3)

(*1) When using accessory pipes 1)-1, 2 (Refer to 6-5 PIPING CONNECTION), provide a service space of at least 12 in.
 (*2) When using accessory pipes 1)-1, 2 (Refer to 6-5 PIPING CONNECTION), provide a service space of at least 14 in.
 (*3) When using accessory pipes 1)-1, 2 (Refer to 6-5 PIPING CONNECTION), provide a service space of at least 16 in.

— **NOTE** —

- Study if the installation location is strong enough to hold the weight of the unit, and if necessary reinforce the area with a beam or other member and then install suspension bolts. Use the suspension bolts to install the unit. (Refer to “4. PREPARATIONS BEFORE INSTALLATION”)
- Install the BS unit and its power supply wiring and transmission wiring at least 40 in. away from televisions and radios to prevent image distortion and noise in those devices. Noise may still be introduced at this distance depending on the electromagnetic wave conditions.

4. PREPARATIONS BEFORE INSTALLATION

Refer the figure 3 and install the suspension bolts and hanging brackets.

<Suspension bolts: For supporting the product>

- Use M8-M10 suspension bolts.
- When holes are to be made anew, used embedded inserts and embedded foundation bolts. When holes are already provided, use hole-in-anchors or the like.
 Install the BS unit so that its weight can be withstood.

<Hanging bracket: For supporting the connection pipe>

- Be sure to support the connection piping around the unit using hanging brackets that are kept within 40 in. of the body side surface. Hanging excessive weight on the BS unit hanging bracket could cause the unit to fall and injure someone.

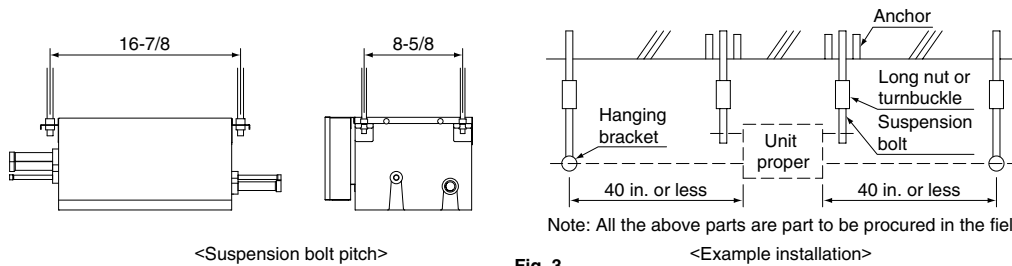

5. BS UNIT INSTALLATION

Use only accessories and parts which are of the designated specification when installing.

(1) When necessary, use the following procedure to change the Electrical Components Box mounting surface.

(Refer to Fig. 4)

- 1) Remove the Electrical Components Box lid. (2 screws)
- 2) Remove the Electrical Components Box. (2 screws)
- 3) Remove the top panel. (4 screws)
- 4) Remove the coil cover. (1 screw)
- 5) Change the pull out direction of the wire (motorized valve coil) between the body and the Electrical Components Box.
- 6) Rotate the coil cover 180° and attach it.
- 7) Turn the top panel around 180° and attach it.
- 8) Attach the Electrical Components Box.
- 9) Attach the Electrical Components Box lid.

(2) Attach the hooks to the suspension bolts.

Be sure to use the nuts (M8 or M10: 3 pcs, 4 locations) and washers (field supply) from both the top and bottom sides of the hanging bracket and make sure they are tightened correctly.

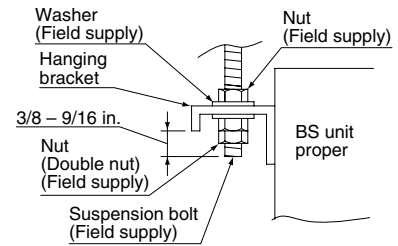

NOTES

- The BS unit has a top and a bottom, so install it so that the diagonal lines in the figure 4 are where the top is. (Failing to do so may prevent the unit from operating properly and increase the volume of the operating noise.)

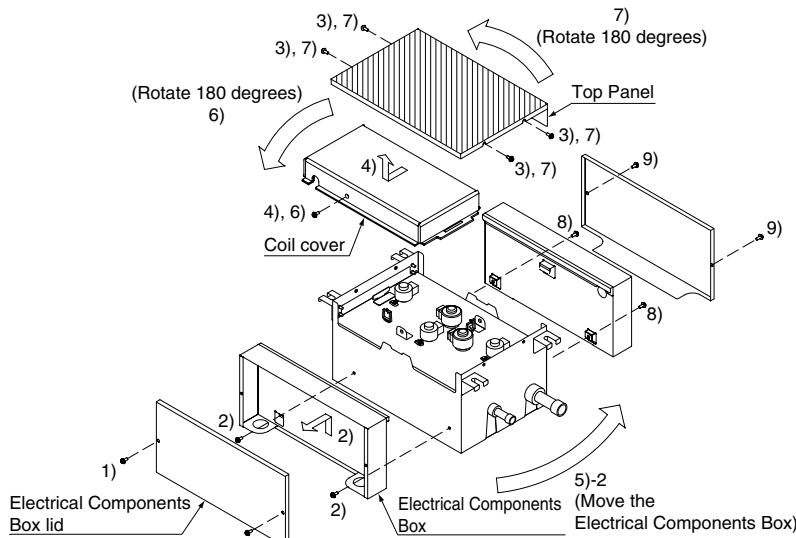
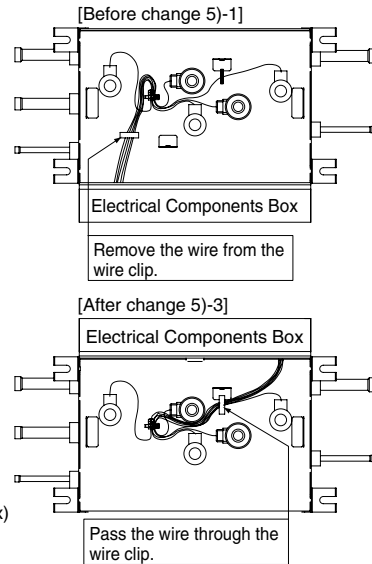

Fig. 4



6. REFRIGERANT PIPING WORK

- For instruction for installing piping between the outside unit and BS unit, selecting a refrigerant branch kit, and installing piping between the refrigerant branch kit and the indoor unit, refer to the installation manual and equipment design materials included with the outside unit.
- Before beginning the work, always check to make sure the type of refrigerant used is R410A. (The unit will not operate correctly with a different type of refrigerant.)
- Insulate all of the piping including the liquid pipes, HP/LP gas pipes, suction gas pipes, gas pipes, equalizer pipes (piping between outside units when an outside multi-unit system), and the pipe connections for these. Not insulating these pipes could result in water leaks or burns. In particular, suction gas flows in the HP/LP gas piping during full cooling operation, so the same amount of insulation as used for the suction gas piping is required. In addition, high-pressure gas flows in the HP/LP gas piping and gas piping, so be sure to use insulation that is designed for use with HVAC Systems.
- Reinforce the insulation material when necessary for the installation environment. Refer to the following as a guideline.
 - For 86°F, RH75% to 80%: Thickness at least 9/16 in.
 - For 86°F, over RH80%: Thickness at least 13/16 in.
 If not reinforced, condensation could form on the surface of the insulation. For details, refer to the Engineering data book.

NOTES

- This product only uses the new refrigerant (R410A). Be sure to use the special pipe cutters for R410A, during installation.
- Make sure that nothing besides the specified refrigerant, such as air, gets into the refrigerant piping.
- If refrigerant gas leaks during the work, ventilate the area. (The outside units are filled with refrigerant.)

6-1 PIPING MATERIAL SELECTION

- Use only pipes which are clean inside and outside and which do not accumulate harmful sulfur, oxidants, dirt, cutting oils, moisture, or other contamination. (Foreign materials inside pipes including oils for fabrication must be 9 mg/10 ft or less.)
- Use the following items for the refrigerant piping.
 - Material:** Jointless phosphor-deoxidized copper pipe
 - Size:** See “Example of connection” to determine the correct size.
 - Thickness:** Select a thickness for the refrigerant piping which complies with national and local laws. For R410A, the design pressure is 478 psi.
- For information regarding the piping allowable maximum length, allowable height difference, and allowable length after a branch, refer to the installation manual that came with the outside unit or Engineering data book.
- The refrigerant branch kit (sold separately) is required for piping branches. For information on how to select a refrigerant branch kit, refer to the Installation Manual that came with the outside unit or Engineering data book.

6-2 PROTECTION AGAINST CONTAMINATION WHEN INSTALLING PIPES

Protect the piping to prevent moisture, dirt, dust, etc. from entering the piping.

Place	Installation period	Protection method
Outdoor	More than a month	Pinch the pipe
	Less than a month	Pinch or tape the pipe
Indoor	Regardless of the period	

NOTE

Exercise special caution to prevent dirt or dust when passing piping through holes in walls and when passing pipe edges to the exterior.

6-3 PIPING CONNECTION WORK PRECAUTIONS

- When brazing refrigerant piping, begin working after replacing the nitrogen (*1) or perform brazing while nitrogen is flowing in the refrigerant piping (*2) (Refer to Fig. 5), and at the end made the indoor unit and BS unit flare or flange connections.
- (*1) For details on nitrogen replacement, see the “VRV Installation Manual” (available at any Daikin dealer).
- (*2) The pressure regulator for the nitrogen released when doing the brazing should be set to about 2.9 psi (Enough to feel a slight breeze on your cheek).

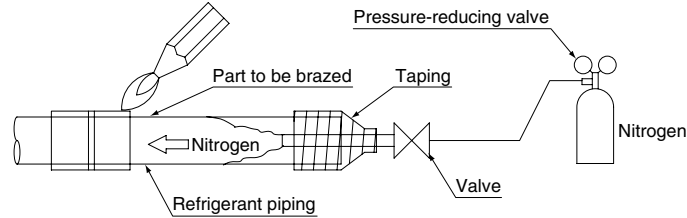

Fig. 5

NOTES

- Do not use an anti-oxidizing agent when brazing the piping. Residual debris could clog the piping or cause parts to malfunction.
- Do not use a flux when brazing the refrigerant pipe joints. Using a chlorine flux may cause the pipes to corrode, and if it contains fluoride it may cause the refrigerant lubricant to deteriorate, adversely affecting the refrigerant piping system. Use phosphor copper brazing (B-Cu93P-710/795: ISO 3677) which does not require flux.

6-4 PIPING SIZE SELECTION

From **Example of connection 1** and **2** below and **Table 1, 2**, select the piping size between the outside unit (refrigerant branch kit) and BS unit, and between the BS unit and the indoor unit (refrigerant branch kit).

Example of connection 1: When 1 indoor unit is connected downstream from the BS unit

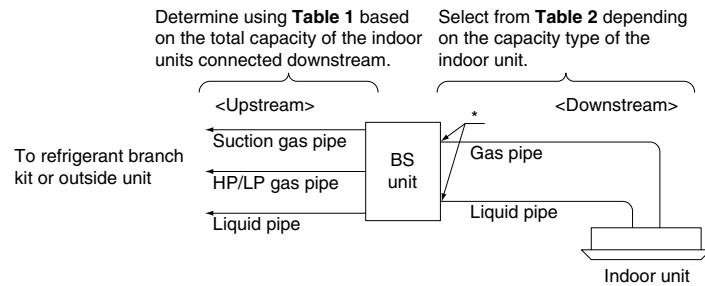

Example of connection 2: When there is a branch downstream from the BS unit

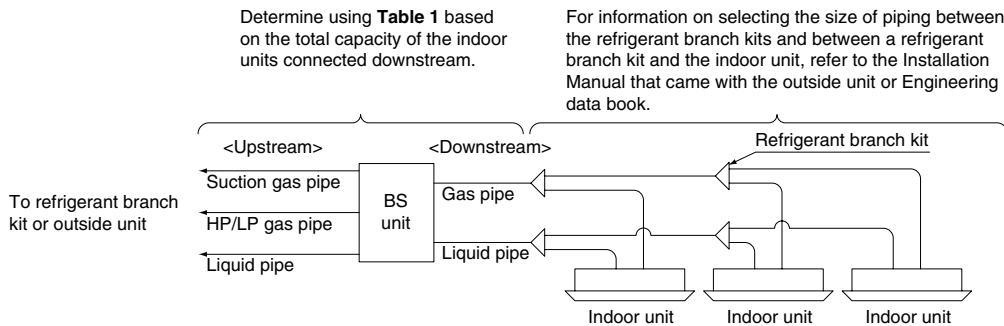

Table 1 Indoor unit total capacity and pipe size

(in.)

Total capacity of indoor units (Q)	Piping size (outer diameter)			
	Upstream		Downstream	
	Suction gas pipe	HP/LP gas pipe	Liquid pipe	Gas pipe
Q < 54	φ5/8	φ1/2	φ3/8	φ5/8
54 ≤ Q < 72	φ3/4	φ5/8		φ3/4
72 ≤ Q ≤ 96	φ7/8	φ3/4		φ7/8

Table 2 Indoor unit connection pipe size

(in.)

Capacity type of indoor units	Piping size (outer diameter)	
	Gas pipe	Liquid pipe
07 · 09 · 12 · 18	φ1/2	φ1/4
24 · 30 · 36 · 48	φ5/8	φ3/8
72	φ3/4	
96	φ7/8	

* The BS unit downstream connection pipe sizes are shown below. If the pipe diameter differs from that of the indoor unit connection pipe size selected from **Table 2**, follow the instructions in “6-5 PIPING CONNECTION” and use the included pipe to make the connection.

Table 3 BS unit connection pipe size

(in.)

BS unit	Piping size (outer diameter)	
	Gas pipe	Liquid pipe
BSVQ36P	φ5/8	φ3/8
BSVQ60P		
BSVQ96P	φ7/8	

6-5 PIPING CONNECTION

Follow the connection example below and connect the site piping.

BSVQ36P type

When the downstream indoor unit total capacity is 36 or less and when one indoor unit with a capacity of 24 to 36 is connected downstream.

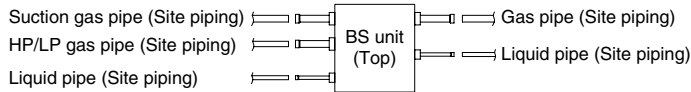

When one indoor unit with a capacity of 07 to 18 is connected downstream

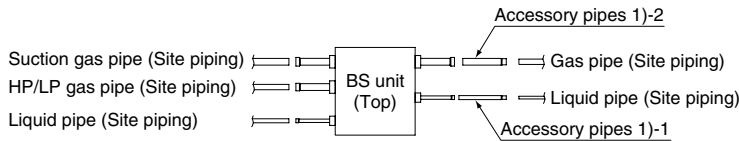

BSVQ60P type

When the downstream indoor unit total capacity is more than 36 but less than 54 and when one indoor unit with a capacity of 48 is connected downstream.

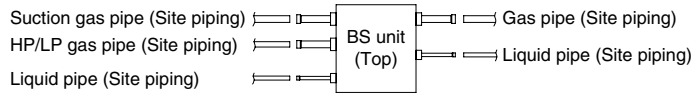

When the downstream indoor unit total capacity is 54 or more but 60 or less

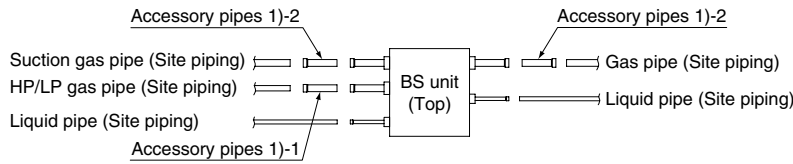

BSVQ96P type

When the downstream indoor unit total capacity is more than 60 but less than 72

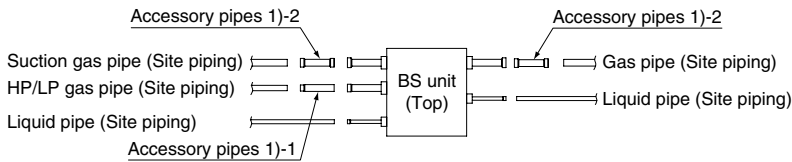

When the downstream indoor unit total capacity is 72 or more but 96 or less and when one indoor unit with a capacity of 96 is connected downstream.

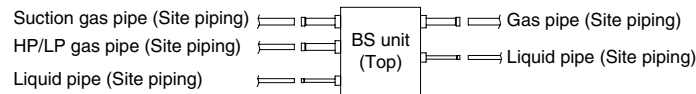

When one indoor unit with a capacity of 72 is connected downstream

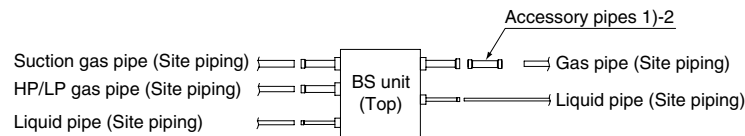

6-6 PIPING INSULATION

- After the gas leak inspection is completed, refer to the following figures and use the included insulation tube 3) and clamps 2)-2 to apply the insulation.

NOTES

- Insulate all of the piping including the liquid pipes, HP/LP gas pipes, suction gas pipes, gas pipes, and the pipe connections for these. Not insulating these pipes could result in water leaks or burns. In particular, suction gas flows in the HP/LP gas pipes during full cooling operation, so the same amount of insulation as used for the suction gas pipes is required. In addition, high-pressure gas flows in the HP/LP gas pipes and gas pipes, so be sure to use insulation that is designed for use with HVAC Systems.
- When reinforcing the insulation material for the installation environment, also reinforce the insulation on the piping protruding from the unit and on the pipe connections. Locally purchase the insulation required for the reinforcement work.

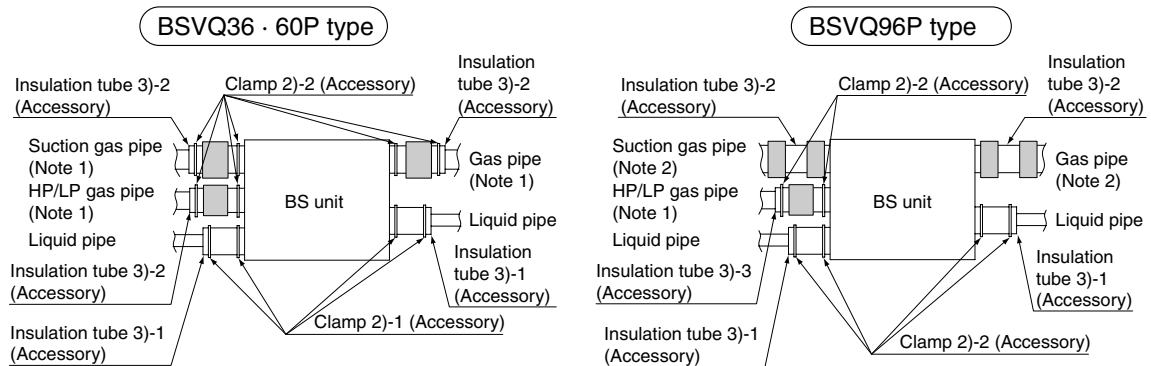

Insulation Attachment Instructions

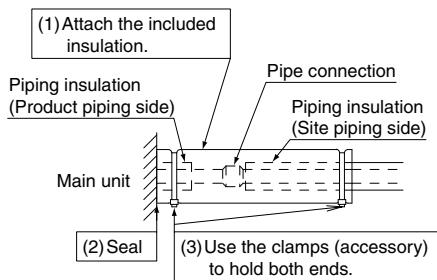

Note 1: For suction gas pipes, HP/LP gas pipes, and gas pipes, after attaching the included insulation tube, wrap more insulation (field supply) around the connections.

Note 2: For Model Q96, wrap sealing material (field supply) around the insulation tube 3)-2 BS unit side and site piping side connections to seal them.

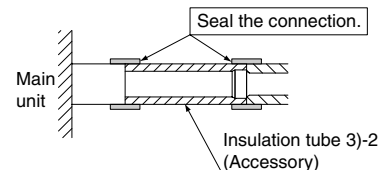
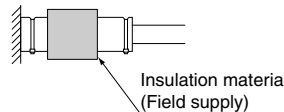

— Insulation Installation Precautions —

1. Seal so that air cannot be in and out of the end.
2. Do not over tighten the clamp so as to maintain the insulation thickness.
3. Be sure to attach the insulation (field supply) with the seams facing up.
(See figure at right.)

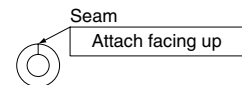

7. ELECTRIC WIRING WORK

7-1 GENERAL INSTRUCTIONS

- All wiring must be performed by an authorized electrician.
- All field supplied parts and materials, electric works must conform to local codes.
- Always ground wires. (In accordance with national regulations of the pertinent country.)
- Always turn off the power before performing the electric wire installation work.
- Follow the “WIRING DIAGRAM” attached to the unit body to wire the outside unit and indoor units.
- Properly connect wire of the specified wire type and copper thickness. Also use the included clamp to avoid applying excessive force to the terminal (field wire, ground wire).
- Do not let the ground wire should come in contact with gas pipes, water pipes, lighting rods, or telephone ground wires.
 - Gas pipes: gas leaks can cause explosions and fire.
 - Water pipes: cannot be grounded if hard vinyl pipes are used.
 - Telephone ground and lightning rods: the ground potential when struck by lightning gets extremely high.
- A circuit breaker capable of shutting down the power supply to the entire system must be installed.
- This system consists of multiple BS units. Mark each BS unit as unit A, unit B . . . , and be sure the terminal board wiring to the outside unit and indoor unit are properly matched. If wiring and piping between the outside unit, BS unit and an indoor unit are mismatched, the system may cause a malfunction.
- Do not turn on the power supply (branch switches, overload interrupters) until all other work is done.

7-2 EXAMPLE FOR THE WHOLE SYSTEM

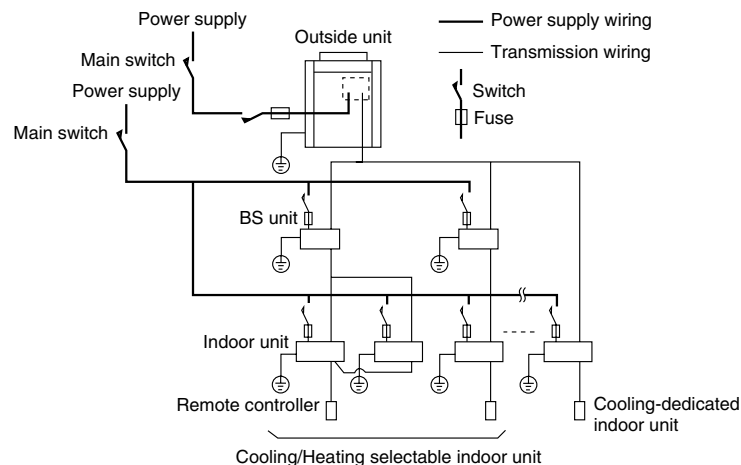

7-3 POWER CIRCUIT, SAFETY DEVICE AND CABLE REQUIREMENTS

- A power circuit (Refer to Table 3) must be provided for connection of the unit. This circuit must be protected with the required safety devices, i.e. a main switch, a slow blow fuse on each phase and the ground fault circuit interrupter.
- When using residual current operated circuit breakers, be sure to use a high-speed type (0.1 second or less) 30mA rated residual operating current.
- Use copper conductors only.
- Use insulated wire for the power cord.
- Select the power supply cable type and size in accordance with relevant local and national regulations.
- Use 18-2 AWG, 2-conductor, stranded, non-shielded copper cable / PVC or vinyl jacket.

Table 3

Model	Type	Hz	Units			Power supply	
			Voltage	Min.	Max.	MCA	MFA
BSVQ36P BSVQ60P BSVQ96P	VJ	60	208~230	187	253	0.1	15

MCA: Min. Circuit Amps (A); MFA: Max. Fuse Amps (A)

NOTES

- The above Table 3 of Electrical Characteristics refers to one BS unit.
- See the Engineering data book for other details.

7-4 WIRING EXAMPLE

- Here is shown a wiring example for one system transmission wiring.
- Connect terminals F1 and F2 (TO IN/D UNIT) on the control PCB (A1P) in the outside unit Electrical Components Box and terminals F1 and F2 (TO OUT/D UNIT) of the control PCB (A1P) of the first BS unit A.

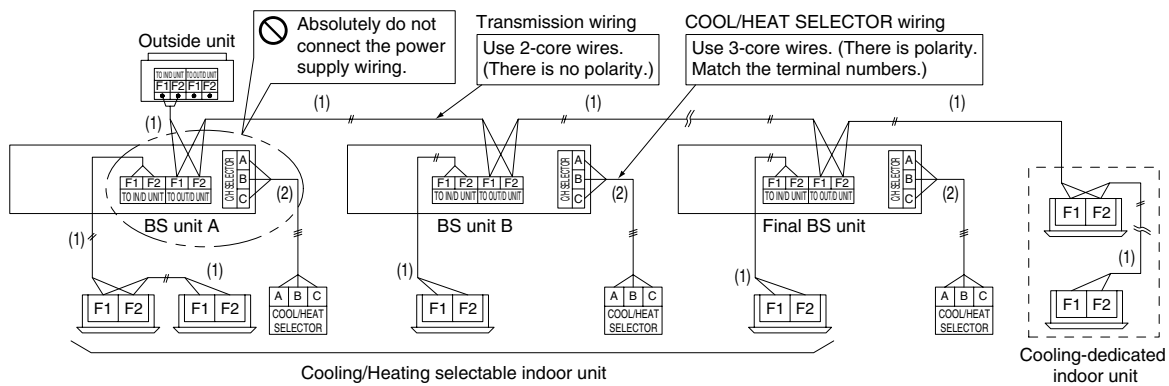

NOTE

1. Connect cooling-dedicated air conditioners to terminals F1 and F2 (TO OUT/D UNIT) of the final BS unit.
2. Use 2-core wire for the transmission wiring. Using a multi-core wire with 3 or more cores when two or more indoor units are used at once could cause abnormal stoppage. (Only use 3-core wire in the COOL/HEAT SELECTOR.)
3. Absolutely do not connect the power supply wiring to the transmission wiring terminal block. Doing so could damage the entire system.
4. For the transmission wiring, use wire that is within the following ranges. Exceeding these limits could cause a transmission error.
 - (1) Between an outside unit and BS unit,
Between a BS unit and indoor unit, and
Between a BS unit and BS unit
Maximum wiring length: 3280 ft or less
Total wiring length: 6560 ft or less
Branch point max: 16 branch points
 - (2) Between a BS unit and COOL/HEAT SELECTOR
Maximum wiring length: 1640 ft or less

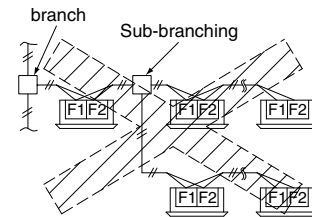

7-5 WIRING CONNECTIONS

Remove the Electrical Components Box lid on the side and follow the directions to connect the wires.

⟨Transmission wiring⟩

Remove the Electrical Components Box lid and connect the wires to F1 and F2 (TO IN/D UNIT) and F1 and F2 (TO OUT/D UNIT) transmission wiring terminals (control PCB (A1P)).

At this time, pass the wiring into the unit through the wiring through hole (left) and use the included clamps 2) to securely hold the wires (in 2 places).

⟨Power supply wiring and ground wire⟩

Remove the Electrical Components Box lid and connect the power supply wiring to the power terminal block (X1M).

Also connect the ground wire to the ground wire terminal. Pass both the power supply wire and the ground wire together through the wire through hole (right) and into the Electrical Components Box and use the included clamps 2) to securely hold the wires (in 2 places).

Be sure to wire the ground wire so that comes out of the slit in the cup washer.

(Not doing so could cause insufficient ground wire contact and causing the wire not to function as a ground.)

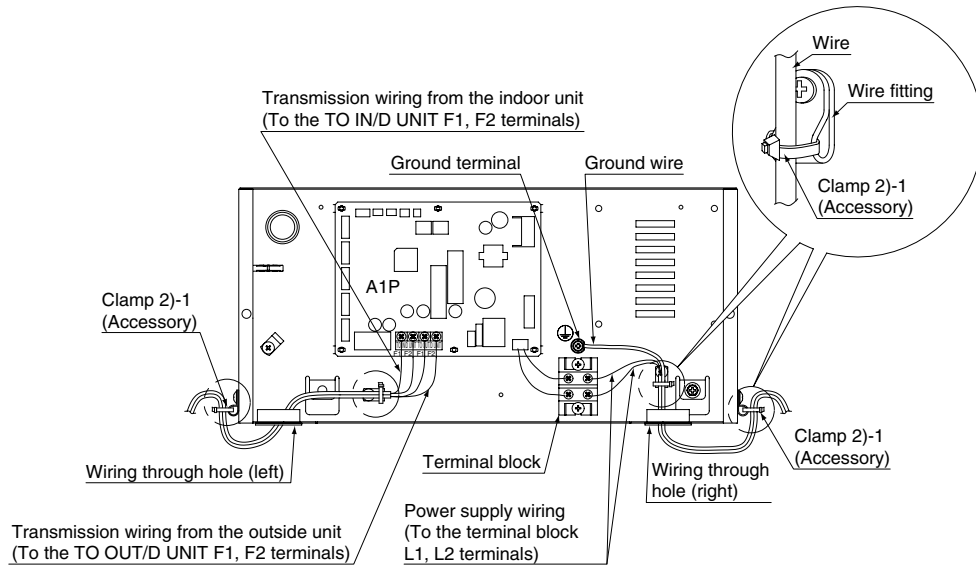
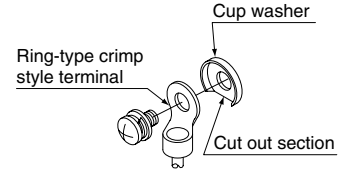

NOTES

- Use ring-type crimp style terminal for connections to the power terminal block. (Refer to Fig. 6)
Also, insulate the crimped area by attaching an insulation sleeve, etc.
If these are not available, see the following section.
 - (a) Wiring of different thicknesses cannot be connected to the power terminal block.
(A loose connection could cause abnormal heating.)
 - (b) When connecting wire of the same diameter, make the connection as shown in the figure 7.
- Use an appropriate screwdriver for tightening the terminal screw.
Using a screwdriver that is too small could damage the screw head and prevent proper tightening.
- Over tightening the terminal screw could damage the screw.
Refer to the Table 4 for the terminal screw tightening torque.
- When fastening the wire, use the included clamp 2)-1 so as not to apply tensile force to the wire connection and then securely fasten the wire. Also, after wiring is completed, organize the wiring so that the Electrical Components Box lid does not pop up and then properly replace the Electrical Components Box lid.
Make sure no wires are pinched when replacing the Electrical Components Box lid.
Always use the wire through hole to protect the wires.
- Do not pass the transmission wiring and power supply wiring through the same locations and outside of the unit keep them separated by at least 2 in..
Not doing so could cause the transmission wiring to pick up electric noise (external noise) and result in a malfunction or breakdown.
- After the wiring working is complete, use sealer (field supply) to seal closed the wire through hole.
(Entry by small animals, etc., could cause a malfunction.)

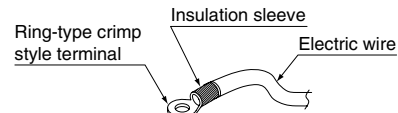

Fig. 6

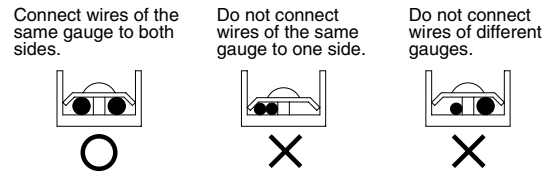

Fig. 7

Table 4

Terminal screw size	Tightening torque (ft · lbf)
M3.5 (COOL/HEAT SELECTOR/transmission wiring terminal block (A1P))	0.58-0.71
M4 (Power supply terminal block)	0.87-1.06
M4 (Ground terminal)	1.12-1.37

8. INITIAL SETTING

- When the refrigerant piping and wire installation work is completed, make the following settings as required.
 - 1. Setting for when connecting the COOL/HEAT SELECTOR to the BS unit.**

<Setting description>

Set the input signal from the COOL/HEAT SELECTOR (sold separately) to ON/OFF.

<Setting method>

Set the dip switches (DS1-1) on PCB (A1P) as shown at left before turning on the power to the BS unit.

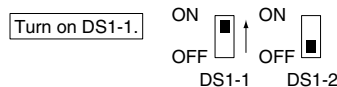

NOTES

This setting is read by the microcomputer when the BS unit power is turned on.

- Be sure to make the setting before turning on the power.
- Always close the Electrical Components Box lid after making the setting.

2. Setting when changing the “Automatic mode differential” in the Cooling/Heating Automatic Operation Mode.

⟨Setting description⟩

- The “Automatic mode differential” can be changed within the range of 0°F to 12.6°F (0°F at factory shipment).
- For details regarding the “Automatic mode differential” and indoor unit operation, refer to the “Engineering data book”.

⟨Setting method⟩

The setting is made using the “Local Setting Mode” by the remote controller of indoor unit connected to the BS unit. For information regarding the setting method, refer to “Engineering data book”.

The following table gives a list of the “MODE NO.,” “FIRST CODE NO.,” and “SECOND CODE NO.”

NOTES 

This setting is operated by the operation remote controller while the indoor unit power is turned on.

- When the indoor unit, outside unit, and BS unit installation work is completed, confirm that it is safe even with the power turned on before proceeding with the work.

MODE NO.	FIRST CODE NO.	SECOND CODE NO.	Automatic mode differential (°F)
12 (22)	4	1	0
		2	1.8
		3	3.6
		4	5.4
		5	7.2
		6	9.0
		7	10.8
		8	12.6

← At factory shipment.

9. TEST OPERATION

- (1) Check to make sure the Electrical Components Box lid is closed.
- (2) Refer to the Installation Manual included with the outside unit and conduct a test run.
 - Clicking or humming sounds will continue for about 20 sec immediately after the power is turned on due to the start of automatic initialization operation (closing) of the solenoid valve, but this is not a problem.

Warning



- Daikin Industries, Ltd.'s products are manufactured for export to numerous countries throughout the world. Daikin Industries, Ltd. does not have control over which products are exported to and used in a particular country. Prior to purchase, please therefore confirm with your local authorised importer, distributor and/or retailer whether this product conforms to the applicable standards, and is suitable for use, in the region where the product will be used. This statement does not purport to exclude, restrict or modify the application of any local legislation.
- Ask a qualified installer or contractor to install this product. Do not try to install the product yourself. Improper installation can result in water or refrigerant leakage, electrical shock, fire or explosion.
- Use only those parts and accessories supplied or specified by Daikin. Ask a qualified installer or contractor to install those parts and accessories. Use of unauthorised parts and accessories or improper installation of parts and accessories can result in water or refrigerant leakage, electrical shock, fire or explosion.
- Read the User's Manual carefully before using this product. The User's Manual provides important safety instructions and warnings. Be sure to follow these instructions and warnings.

If you have any enquiries, please contact your local importer, distributor and/or retailer.



Cautions on product corrosion

1. Air conditioners should not be installed in areas where corrosive gases, such as acid gas or alkaline gas, are produced.
2. If the outdoor unit is to be installed close to the sea shore, direct exposure to the sea breeze should be avoided. If you need to install the outdoor unit close to the sea shore, contact your local distributor.



JMI-0107

Organization:
DAIKIN INDUSTRIES, LTD.
AIR CONDITIONING MANUFACTURING DIVISION

Scope of Registration:
THE DESIGN/DEVELOPMENT AND MANUFACTURE OF COMMERCIAL AIR CONDITIONING, HEATING, COOLING, REFRIGERATING EQUIPMENT, COMMERCIAL HEATING EQUIPMENT, RESIDENTIAL AIR CONDITIONING EQUIPMENT, HEAT RECLAIM VENTILATION, AIR CLEANING EQUIPMENT, MARINE TYPE CONTAINER REFRIGERATION UNITS, COMPRESSORS AND VALVES.



JQA-1452

Organization:
DAIKIN INDUSTRIES
(THAILAND) LTD.

Scope of Registration:
THE DESIGN/DEVELOPMENT AND MANUFACTURE OF AIR CONDITIONERS AND THE COMPONENTS INCLUDING COMPRESSORS USED FOR THEM



EC99J2044

All of the Daikin Group's business facilities and subsidiaries in Japan are certified under the ISO 14001 international standard for environment management.

Dealer

DAIKIN AC (AMERICAS), INC.
1645 Wallace Drive, Suite 110
Carrollton, TX 75006
info@daikinac.com
www.daikinac.com

©All rights reserved